

a proud community; where residents can call a safe, clean and attractive borough their home.

POLICY COMMITMENT

1. Create stronger neighbourhoods: work with Kent Police on the prevention, detection and reduction of crime and anti-social behaviour, and the safeguarding of local residents.

Key work completed or supported by the Community Safety Unit (CSU) during Quarter 2:

- Work in Gravesend Town Centre over the summer period has concentrated on the Fort Gardens, Gordon Promenade, Chantry Gardens and Woodlands Park. Security officers patrolled daily between the afternoon and early evening, liaising regularly with local PCSOs, to provide an additional uniformed presence. Engagement with the public during patrols also provided an opportunity for information to be sought to help reduce ASB in future.

- Our CSU has worked closely with The Gr@nd Youth Workers since July, (funded via the Violence Reduction Unit) to carry out targeted youth engagement work in specific locations coming to our attention. Over 50 young people from a wide range of backgrounds, male and female, have been engaging with workers who have signposted them to local activities (both for socialising and to assist for e.g. accessing training opportunities).

- Officers from the CSU and other Council colleagues took part in a multi-agency Police-led Operation, the first two days of which took place in September, to tackle the sale of illegal cigarettes and tobacco in shops in the town centre. Some very positive results were achieved: 6 shops were searched, 21,000 cigarettes, 102 pouches of tobacco, 10 mobile phones, 2 vehicles and £1,375 in cash were all seized and sophisticated concealed compartments were found in several of the premises. Work to address this issue and the potential serious risk to health, will continue to take place in Quarter 3 and is also a priority area of work for the Gravesham Community Safety Partnership's Serious Organised Group.

- Safeguarding Training has now been completed by over 200 Council staff to ensure that staff are well-briefed in identifying potential safeguarding risks and how to refer and/or support both young people and adults who may be vulnerable.

- Recorded quarterly crime data suggests a small and slow increase (as expected following significant reductions achieved during the height of the pandemic) but the number of offences recorded in Quarter 2 is still fewer than any quarterly figure recorded in 2019-20 or 2020-21.

- ASB incidents have now fallen to pre-Covid levels and in fact, the month of September recorded 153 incidents which is the smallest number of incidents since December 2019.

PI 1 Total number of reported crime offences

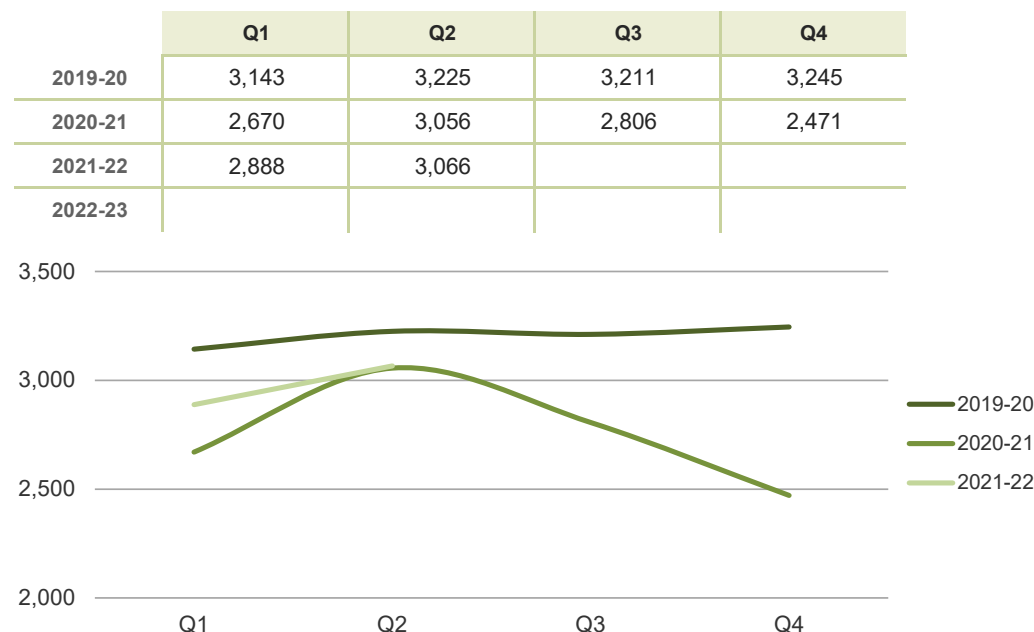

PI 2 Total number of reported incidents of Anti-Social Behaviour

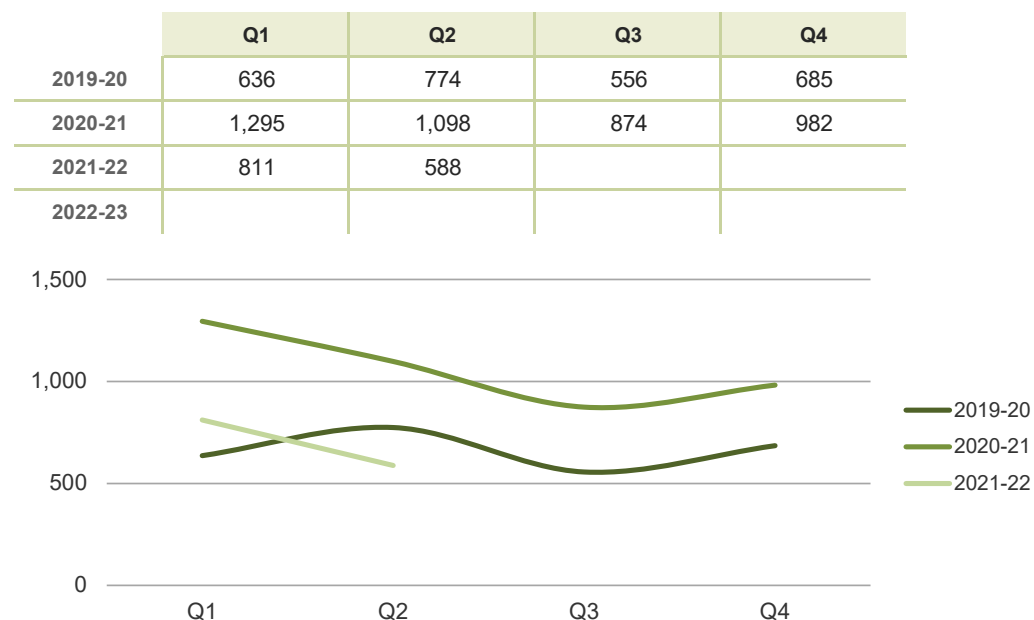

a proud community; where residents can call a safe, clean and attractive borough their home.

POLICY COMMITMENT

2. Actively enforce environmental standards: use available powers to pursue anyone committing environmental crime or damaging the local environment.

The Environmental Enforcement Team currently consists of one investigator and three Street Scene Enforcement Officers.

In Q2 2021/22 the Environmental Enforcement Team have continued to take all reports of fly-tipping, triage those reports, and attend any which may contain evidence or provide lines of enquiry to enable investigation.

During Q2, there were 919 reports. Those reports resulted in 110 investigations and 35 small-scale offence enquiries.

During the period, five cases have been referred to criminal court through our legal team for prosecution and are awaiting court appearance. One case has been heard and resulted in a conviction under S110 of the Environment Act 1995. The offender received a criminal conviction, a conditional discharge and costs.

There have been thirty £400 Fixed Penalty Notices issued for fly tipping and four £150 fines for littering. All outstanding fines have been paid.

In addition, 41 Community Protection Notice Warnings, relating to low-level waste offences, have been issued to residents and businesses.

The team continue to work with internal and external partners to tackle environmental crime and anti-social behaviour. On the 3rd August the team worked with Kent Police and the Environment Agency on a joint proactive operation, during which 7 vehicles were seized for environmental crime related traffic offences.

They have recently begun to deploy covert cameras in areas of high offending and as a result have captured offenders fly tipping, who will face prosecution.

We continue to work closely with the media team to ensure that enforcement successes and educational messages are posted on social and news media.

PI 13 Total number of environmental enforcement actions taken

	Q1	Q2	Q3	Q4
2019-20	17	16	28	19
2020-21	0	7	44	79
2021-22	100	75		
2022-23				

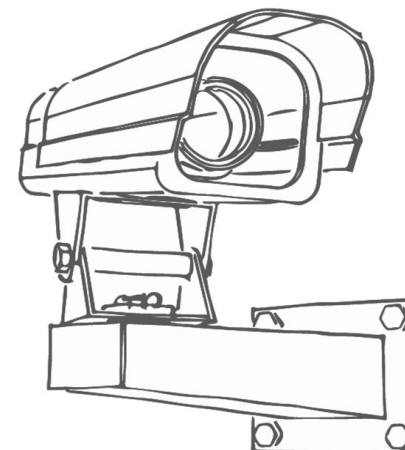
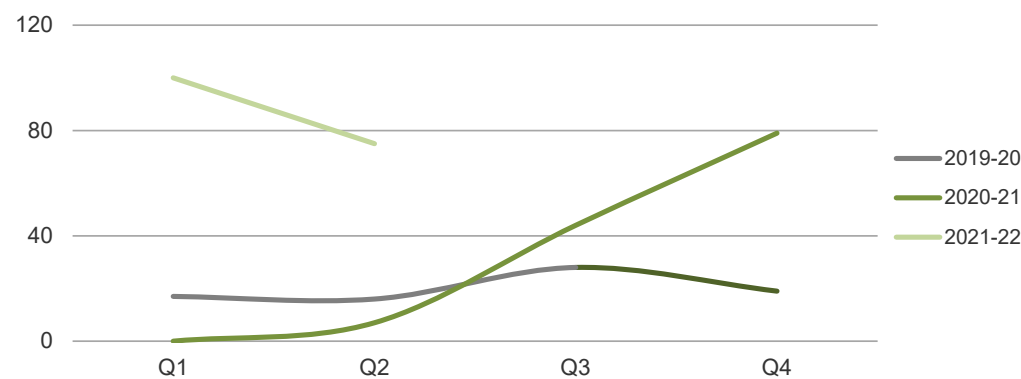

POLICY COMMITMENT

1. Design a quality and affordable leisure offer: improved facilities and creative sports programmes to tackle local health inequalities.

Leisure Centres - During the July to September 2021 monitoring period (Q2), the swimming pool and health suite facilities at Cascades Leisure Centre reopened on the 24 July. This now means that all sports activity areas are now available. The total attendance at Cascades and Cygnet for the July to September 2021 period was 102,871. The total attendance during the corresponding period, pre-pandemic, in 2019 was 207,957. The performance of the swimming pool at Cascades was pleasing, with it being at 71% of the 2019 period. In fact for the month of August, the Cascades swimming pool had the highest level of attendance for the past 7-years at 14,896. The swimming pool at Cygnet was at 55% of the 2019 period.

Both sports halls are performing well, with Cascades at 69% and Cygnet at 100% compared to the 2019 period. Unfortunately the return of squash is not so good with performance figures of 11% and 24% respectively compared to the 2019 period. When comparing gym, group class and health suite attendances to 2019, the following can be noted:

- Cascades Gym is at 54% compared to 2019 – Cygnet Gym is at 46%
- Cascades Group Classes is at 48% compared to 2019 – Cygnet Group Classes is at 41%
- Cascades Health Suite is at 23% compared to 2019 – Cygnet Health Suite is at 37%

By way of summary, the attendance performance is improving but, as expected slowly with GCLL continuing to add to its programme over the next three months.

Active Gravesham – Whilst last year's Summer Fun programme was unable to go ahead, this year we were able to deliver a number of smaller scale events across the borough. These mainly took the form of fun days based across a number of sites, including a weekly 'Fun at the Fort Gardens' throughout August. The Fort sessions included specific heritage activities in the Chantry, as well as storytelling sessions (with Woodville Education and Outreach and KCC Libraries) and 'Magic and Movement' sessions, which included dodgeball, football and magic shows.

North West Kent Countryside Partnership also attended a number of our events to deliver nature trails and pond dipping. We also delivered Tai-Chi sessions, for those aged 14+ across August and 'Introduction to Fishing' sessions at Shorne Woods Country Park. The council, as in previous years, supported the Northfleet Big Local, to deliver family physical activity sessions, which included circuit training and mindfulness meditation, delivered by Primal Roots CIC. It is estimated that just under 700 people participated in planned activities over the summer period.

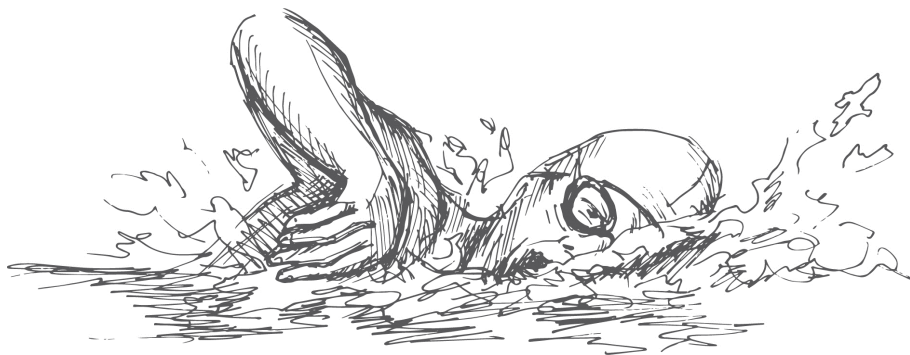

a dynamic borough; defined by a vibrant and productive local economy taking advantage of growth in the area, supported by its strong and active community.

PI 37 Total number of leisure centre attendees

	Q1	Q2	Q3	Q4
2019-20	219,508	207,957	194,043	204,620
2020-21	N/A	41,278	39,391	2,901
2021-22	74,247	102,871		
2022-23				

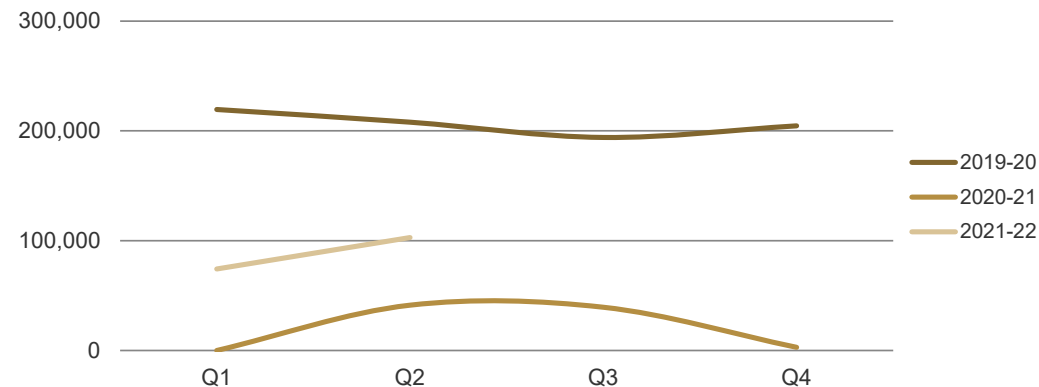

PI 38 Total number of 'Active Gravesham' attendees

	Q1	Q2	Q3	Q4
2019-20	Annual indicator			7,318
2020-21	Annual indicator			551
2021-22	Annual indicator			
2022-23	Annual indicator			

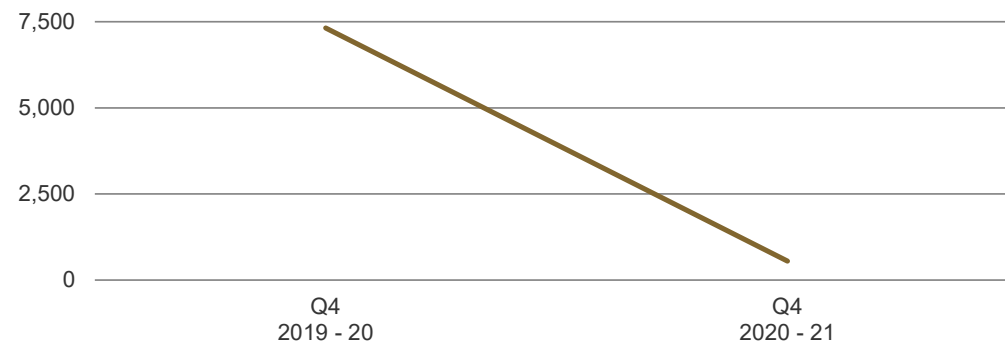

POLICY COMMITMENT

2. Manage a programme of proactive healthy living interventions: work with partners to help support and safeguard vulnerable residents.

Cloud9 Festival is a new creative Wellbeing festival for Ebbsfleet, Swanscombe and Northfleet using creative artists and fitness to create community cohesion and integration. Launch events included a Community Choir, Youth Hip Hop and Words for Windows with a main festival day in July. The Gr@nd also helped bring some of the festival to Northfleet with some of the artists performing in the Hive in Northfleet.

Increasing uptake of the Covid vaccine - working with GBC support was provided for information points within the town alongside the CCG to promote the benefits of the vaccine and encourage the vaccine drop in service.

Age UK - Beginners Digital Tech Course. This course is run in partnership with Age UK North West Kent with 6 participants taking part in the beginners tech course covering topics including laptop basics, online shopping, zoom and much more.

CPR Training working with Gravesham Youth Council CPR training was delivered. This led to 13 people learning lifesaving skills.

GYG Family and Friends Performance at the Gr@nd
The Grand Youth Team have continued to work with the GYG Committee and young performers throughout the lockdowns. The young people who missed out on performing in 2020 were given the chance to perform within The Grand Courtroom, a more intimate setting with friends and family. We have held four separate evenings, and all were well attended.

One You - Grand Active. This quarter saw the One You team bring sessions back into the building and continue to deliver sessions outdoors at the free gym located at the Sikh temple grounds. The hybrid package of delivery helped us retain numbers and work with 43 clients.

a dynamic borough; defined by a vibrant and productive local economy taking advantage of growth in the area, supported by its strong and active community.

PI 40 Total number of people achieving a target outcome from the Gr@nd healthy living services

	Q1	Q2	Q3	Q4
2019-20	974	595	1,011	515
2020-21	353	417	414	386
2021-22	384	359		
2022-23				

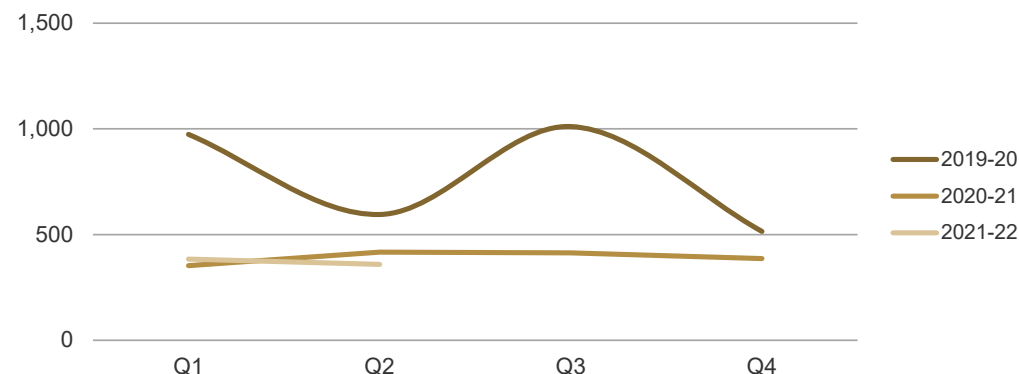

POLICY COMMITMENT

#2 PLACE

3. Develop a cohesive and resilient community: implement a leading programme of engagement initiatives, showcasing the borough's diversity and enabling greater participation in civic life.

With the easing of restrictions we have seen a return of community events with more usual numbers in attendance.

Flag raising on Community Square took place to mark Eid-al-adha and Roma Holocaust. The council's community event fund provided support to enable Roma Holocaust exhibition, a Family Fun Day at Riverside Community Centre and for Gravesham Pride to run the borough's first Pride event at Fort Gardens on Saturday 14 August. The event played to a maximum audience and was a big success.

The many litter picking groups have completed 16 litter picks around the borough during this quarter.

Support has been provided to a wide range of front line community organisations to distribute support to those residents in need of help with food and fuel bills over the summer months.

We have also continued to work with the NHS vaccination team deploying the mobile vaccination bus to the Riverside Community Centre, Cygnets Leisure Centre and Ebbsfleet Football Club.

a dynamic borough; defined by a vibrant and productive local economy taking advantage of growth in the area, supported by its strong and active community.

PI 41 *Total number of community activities/events delivered by the council and in conjunction with its partners*

	Q1	Q2	Q3	Q4
2019-20	Annual indicator			36
2020-21				50
2021-22				
2022-23				

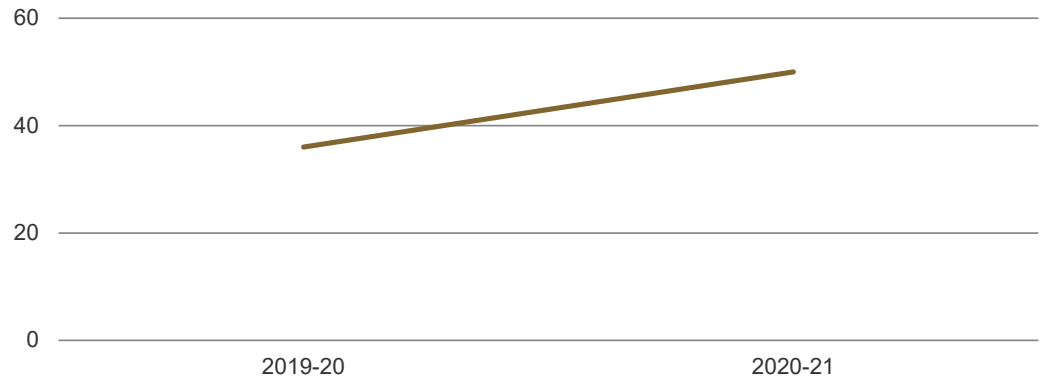

POLICY COMMITMENT

4. Enhance the borough's cultural offer: maximise the usage of The Woodville and the Borough Market as community assets.

The Woodville continued its use as a vaccine centre until the end of August. During that time events were held outside throughout the summer months. These included 4 comedy nights, a night of West End Musical performances, a family show and a two day family festival that coincided with the regatta weekend at the beginning of September. All the ticketed events sold out and plans are in place to enhance this programme in 2022.

We have had increased activity in St Andrew's Arts Centre with it being used for rehearsals for a new dance piece, as well as an arts fair. The railings along the riverfront at St Andrew's Quay have been in use over two bank holiday weekends for local arts groups to exhibit and sell their work. Ticket sales also increased during this quarter due to the new Autumn programme.

Footfall to the Borough market appears in the performance figures to have dipped, this was not actually the case but due to an error with the footfall counters. The market saw an increase in permanent unit uptake with a new clothes trader opening in a double unit and resumed its themed markets with the return of the Vegan market and handmaid fair.



a dynamic borough; defined by a vibrant and productive local economy taking advantage of growth in the area, supported by its strong and active community.

PI 42 Total number of patron tickets sold by The Woodville

	Q1	Q2	Q3	Q4
2019-20	10,658	12,358	21,127	6,968
2020-21	0	2,413	3,415	241
2021-22	107	5,172		
2022-23				

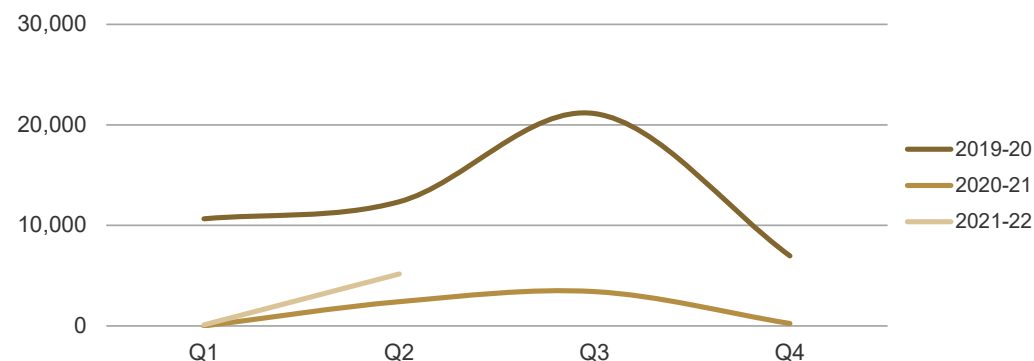

PI 43 Average weekly Borough Market footfall

	Q1	Q2	Q3	Q4
2019-20	6,419	6,801	6,857	7,461
2020-21	980	6,192	4,582	2,223
2021-22	4,681	4,506		
2022-23				

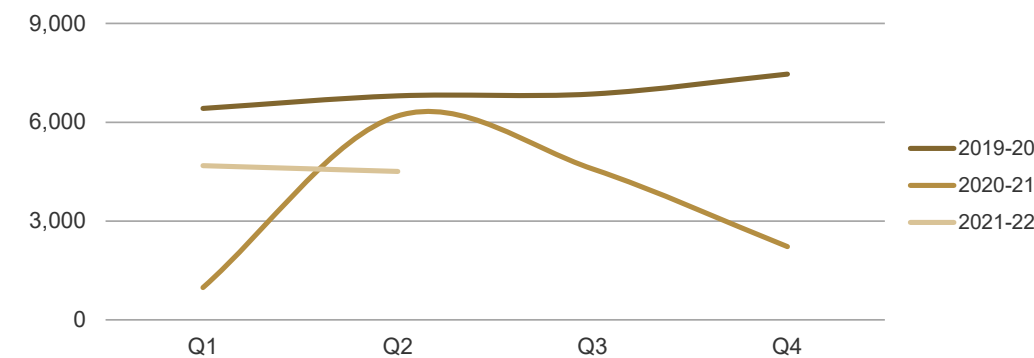

a dynamic borough; defined by a vibrant and productive local economy taking advantage of growth in the area, supported by its strong and active community.

POLICY COMMITMENT

5. Promote Gravesham's arts and heritage: support local groups in their community reach and expand the visitor economy.

The Milton Chantry and New Tavern Fort re-opened following 18 months of closure on 24th July 2021. A small programme of family events was devised to support the re-opening which included opening Milton Chantry every Wednesday in August as part of the Summer Fun programme and special character visits from the Medieval Monk, General Gordon and Alymer de Valence. In addition to this a new children's heritage treasure hunt was created and an indoor fairy door trail for younger visitors.

The new exhibition depicting Barrack life within Milton Chantry has been well received by visitors, especially the costumes and selfie station. Thoughts now turn to the other rooms and improvements in displays and interpretation of exhibits.

The Make it Arts grants partnered with the Blooming Lovely Festival and commissioned three artists to deliver 5 installations throughout the town from July to September. As part of Milton Chantry 700 and the Blooming Lovely Festival, the building hosted its first artist commission, a tapestry piece by Nicola Flower. Nicola hosted a small 'meet the artist' style reception to thank those who participated and explain to other visitors the thinking behind the tapestry. Both sites were open during the Fun in the Fort event on 4 and 5 September and the Hope and Glory event on 25 and 26 September and recorded good visitor numbers.

The Cold War Bunker at Woodlands Park has also resumed its guided tours. Funding has now been received to transfer the existing Audio tours of Milton Chantry, New Tavern Fort and Riverside Walk into apps. This project will begin shortly and will hopefully be ready in time for April 2022 opening.

PI 44 Total number of visitors attending Gravesham heritage sites

	Q1	Q2	Q3	Q4
2019-20	Annual indicator			4,936
2020-21				0
2021-22				
2022-23				

